

ME-CUB 2.0

Motor Control Center
with withdrawable units
up to 6300 A - 105 Ka



GLAFER
Simple ideas for great projects | GROUP

ME-CUB 2.0

Motor Control Center with withdrawable units up to 6300 A - 105 Ka

(IP30 – IP55, from FORM 3 to FORM 4).

A product range designed for motor starting and control. Me-cub 2.0 versatile design can accommodate different sizes of withdrawable units providing a solution to all types of applications.

Main characteristics

- Assembled sheet metal enclosure (upright thickness: 20/10 mm).
- Degree of protection from IP30 (cabinet without door) up to IP55 (cabinet equipped with transparent tempered glass

door).

- Compartment equipped with side and horizontal partitions, rear wiring plate with female connector for auxiliary circuits and power pliers.
- Withdrawable unit equipped with customizable front panel, SwitchLAF™ 2.0 system, male connector for auxiliary circuits and power contacts.
- Possibility of side connection.
- Installation of circuit breakers of all

leading manufacturers (ABB, Schneider, Siemens, etc.).

- RAL 7035 B epoxy powder coating (other colours on request).
- Enclosures available in stainless steel on request.
- Patented and certified earthing system.
- Reinforced plinth for a safe handling of the enclosure.
- Full range of internal finishing accessories to meet any requirement.



Typology



Cabinet with cable compartment: Enclosure compatible with UNIT, 1/2 UNIT and 1/2 FEEDER withdrawable drawers and fixed drawer.
 -Form of segregation (3B-4B-4A)
 -Access to the cabinet for connections: front/rear



Cabinet MULTISWITCH: Enclosure compatible with 1/2 UNIT and 1/2 FEEDER withdrawable drawers.
 • Form of segregation (3B-4B-4A)
 • Access to the cabinet for connections: front/rear



Cabinet with glass door: All available layouts (free-standing cabinet, cabinet with cable compartment or MULTISWITCH cabinet) can be equipped with glass door to achieve an IP55 degree of protection

Certifications



IEC 61439-1	test n. B0008006 test n. B8020497	Short-circuit withstand In=6300 and Icc=105 kA for 1 sec. • Verification of the short-circuit withstand • Verification of the effective connection between the equipment masses and the protection circuit
IEC/TR 61641 CEI 17-86	test n. B0009515	Arc conditions due to internal fault 70 kA for 300 msec
IEC 61439-1 IEC/TR 61641	test n. B0007840	Verification of overtemperature limits • Verification of overtemperature limits • Verification of dielectric properties: industrial frequency and impulse tests • Verification of air clearance and creepage distances
CEI EN 60529	test n. EPT16AVM033754359 test n. EPT16AVM033754359 test n. CESI A902B006 test n. B0011835 test n. B4030377	Verification of degree of IP30 degree of protection Verification of degree of IP41 degree of protection Verification of degree of IP42 degree of protection Verification of degree of IP54 category 2 degree of protection Verification of degree of IP55 category 2 degree of protection Verification of degree of IP56 category 2 degree of protection
IEEE Std 693-2005 IEC 60068-2-57 IEC 62271-300 Transelect	test n. B3020295	Seismic test with acceleration 1,0g



Technical specification

	Width (W) mm	Height (H) mm	Depth (D) mm
Free-standing cabinet	625 (24 modules) 700 (24 modules)	2000 / 2200 / 2400 (usable space = H - 200)	625 / 800 / 1000 / 1200 / 1400 / 1600
Cabinet with cable compartment	625 + 300 (24 modules) 700 + 300 (24 modules)		
	625 + 400 (24 modules) 700 + 400 (24 modules)	2000 / 2200 / 2400 (usable space = H - 200)	625 / 800 / 1000 / 1200 / 1400 / 1600
Multiswitch cabinet	1000 + 300 (44 modules) 1000 + 400 (44 modules)		
Back-to-back cabinet	Available on request		
Electrical data	Rated insulation voltage (U _i)		1000 V
	Rated operational voltage (U _e)		690 V
Voltage ratings	Rated impulse withstand voltage (U _{imp})		6 / 8 / 12 kV
	Rated frequency (f _n)		50 / 60 Hz
Current ratings	Rated current (I _n)		Main busbar system: Fino a 6300A Vertica distribution busbars: 400 / 630 / 800A
	Rated short-time withstand current for 1 sec. (I _{cw})		105 kA
	Permissible current under arcing conditions (I _{p,arc})		70 kA
Internal arc resistance	Permissible arc duration (t _{arc})		300 ms
	Withdrawable units pliers		160 / 320 A
Auxiliary contacts connectors		10 / 16 A	
Auxiliary contacts		6 / 16 / 24 / 42 / 48	
Mechanical Characteristics	IP Degree of protection	Internal: Up to IP2X External: From IP30 to IP55	
	Withdrawable units height (h)	150 / 200 / 250 / 300 / 350 / 400 / 450 / 500 / 600	
	Protection against mechanical impacts (IK code)	IK09 glass door IK10 blind door	
	Access to the cabinet for circuit breakers connection	From the Front/Side/Rear	
	Form of internal separation	Form 3b / Form 4b	
Material	Structure	Pickled plate 15/10 - 20/10 mm thick	
	Accessories	Aluzinc® sheet steel 15/10 - 20/10 mm thick	
Powder coating	Standard	RAL 7035B orange peel	
	On request	RAL shades / stainless steel	
Plastic components	Halogen-free, flame retardants, self-extinguishing, CFC-free		
	Busbar system	Insulated / Silvering / Tin plating Position switch "drawer in test position" Position switch "drawer in disconnected/ connected position" Position switch "drawer in inserted/ withdrawn position" Position switch "drawer in inserted/ remote withdrawn position" (n°2)	

All Lafer cabinets have been designed to be used in indoor environments. In case of outdoor applications, customers should require the supply of the specific rain canopy. Lafer shall not be held liable for any damage resulting from the non-observance of these guidelines.

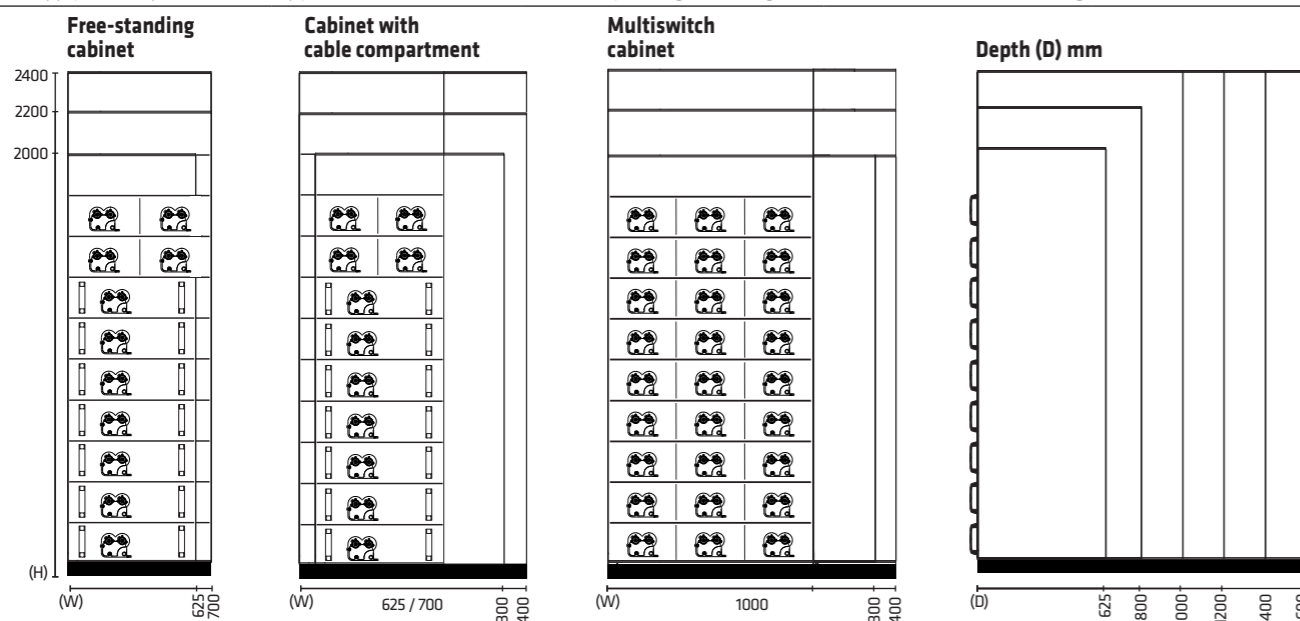

Certifications



Characteristics to be verified	Clause/Subclause	Design verification method	Test report n°		
Degree protection of the assembly of enclosures	10.3	IP30	By test	EPT16AVM033754359 EUROFINS	
		IP41	By test	EPT16AVM033954359 EUROFINS	
		IP42	By test	EPT16AVM034054359 EUROFINS	
		IP55	By test	B0011835 CESI	
Mechanical impacts (IK)	10.2.6	IK9	By test	EPT16AVM034154359 EUROFINS	
		IK10	By test	EPT16AVM033854359 EUROFINS	
Temperature rise limits	10.10.4.2	Single-compartment assemblies with rated current not higher than 630 A	Verification by calculation according to the method of power losses		
		Single or multiple compartment assemblies with rated current not higher than 1600A	Verification by CEI 17-43		
	Appendix of the norm (subclause 7.2 point 3)	Single or multiple compartment assemblies with rated current 1600 A < I _{na} < 3150 A	Verification by CEI 17-43 with confrontation with proved cabinet	B0007840 CESI	
		Single or multiple compartment assemblies with rated current I _{na} > 3150 A	Verification by CEI 17-43 with confrontation with proved cabinet	B0007840 CESI	
Clearances	10.4		By test	Lafer quality control protocol	
Creepage distances	10.4		By test	Lafer quality control protocol	
Verification of the short-circuit withstand of the protection circuit	10.5.3	Flat copper 60 kA	- By test - By comparison with a reference design	B0015061 CESI	
		Extruded aluminium 60 kA	- By test - By comparison with a reference design	B7001848 CESI	
		Flat aluminium 60 kA	- By test - By comparison with a reference design	B6004584 CESI	
		Smart Energy 35 kA	- By test - By comparison with a reference design	B3012744 CESI	
Verification of the short-circuit withstand strength	10.11	Smart Energy 70 kA	- By test - By comparison with a reference design	B3013956 CESI	
		Switchlaf Flat copper 70 kA	- By test - By comparison with a reference design	B0015061 CESI	
		Switchlaf 2.0 Smart Energy Plus Smart Energy Copper 75 kA	- By test - By comparison with a reference design	B8020497 CESI	
		Smart Energy Copper 105 kA	- By test - By comparison with a reference design	B8020496 CESI	
		Smart Energy Plus 105 kA	- By test - By comparison with a reference design	B5002265 CESI	
		Smart Energy Plus 105 kA	- By test - By comparison with a reference design	B7001848 CESI	
		Seismic test	0.7 g	By test	B3020325 CESI
		1 g	By test	B3020295 CESI	



Constructive section

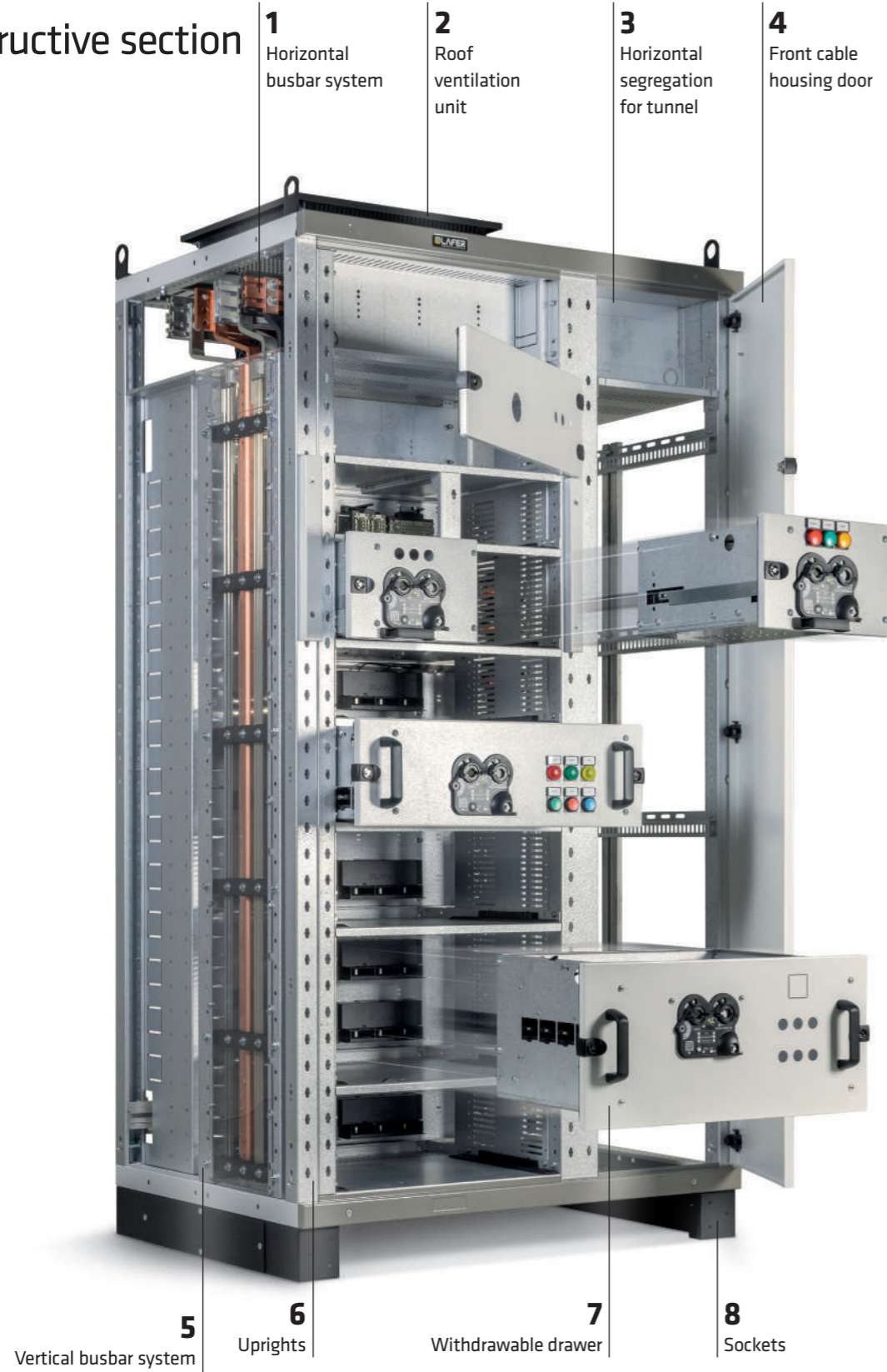

1
Horizontal
busbar system

2
Roof
ventilation
unit

3
Horizontal
segregation
for tunnel

4
Front cable
housing door

5
Vertical busbar system

6
Uprights

7
Withdrawable drawer

8
Sockets

Outer details

Vertical distribution busbars and main horizontal busbar system

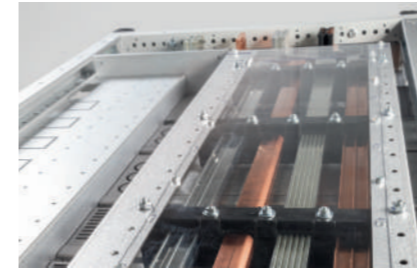

Vertical distribution busbars up to 800A:
Available solutions: aluminium or copper profiles, flat copper or tin-plated copper bars



Main horizontal busbar system up to 4000A:
Available solutions: aluminium, copper or silver-plated copper profiles, copper profiles treated with protective coat or flat copper bars



Main horizontal busbar system partitions:
Sheet steel partition to prevent any contact with live parts

Cable compartment



Lateral compartment for terminal block and aluminium or copper earth bar

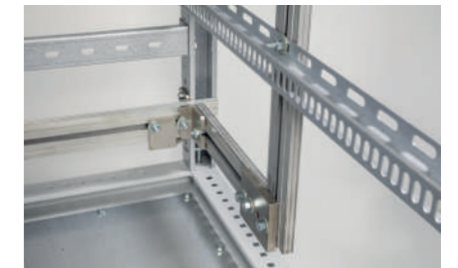

Inner details

CFixed compartments for Unit, 1/2 Unit and 1/2 Feeder drawers



UNIT

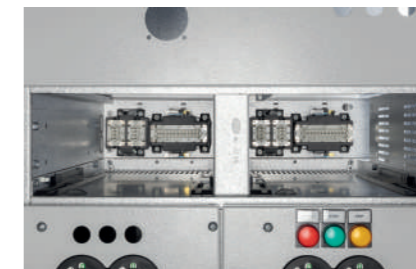

1/2 UNIT



1/2 FEEDER

Unit, 1/2 Unit and 1/2 Feeder withdrawable drawers



UNIT



1/2 UNIT



1/2 FEEDER



Download the brochure
of the ME-Cub series



Download the datasheet
of the ME-Cub series



Download the construction
module of the ME-Cub
series

Withdrawable drawer UNIT

Suitable for applications from 18.5 Kw up to 200 kw

MOTOR STARTING UNIT

3-pole UNIT withdrawable drawer

4-pole UNIT withdrawable drawer

Available degrees of protection: IP30-IP42-IP55

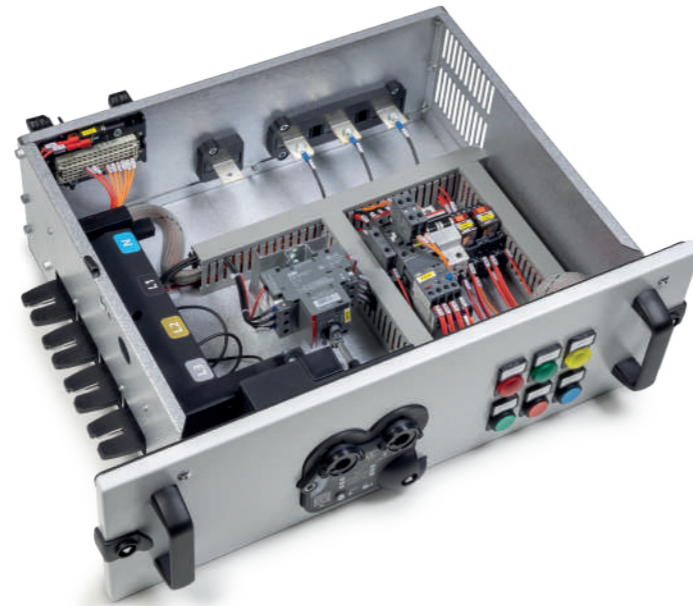
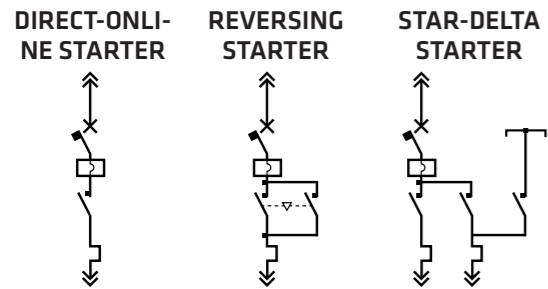

Motor starting typologies UNIT

400 V				690 V			
Withdrawable drawer height mm	Direct-online starter kW	Reversing starter kW	Star-delta starter kW	Withdrawable drawer height mm	Direct-online starter kW	Reversing starter kW	Star-delta starter kW
150	≤ 18.5	≤ 18.5	≤ 11	150	≤ 18.5	≤ 18.5	≤ 11
200	≤ 30	≤ 30	≤ 18.5	200	≤ 37	≤ 37	≤ 30
250	≤ 45	≤ 45	≤ 30	250	≤ 75	≤ 75	≤ 55
300	≤ 75	≤ 75	≤ 45	300	≤ 110	≤ 110	≤ 75
400	≤ 110	≤ 110	≤ 75	400	≤ 160	≤ 160	≤ 110
500	≤ 132	≤ 132	≤ 110	500	≤ 200	≤ 200	≤ 160
600			≤ 132	600			≤ 200

Withdrawable drawer 1/2 UNIT

Suitable for applications from 7.5 kW up to 22 kW

MOTOR STARTING UNIT

3-pole 1/2 UNIT withdrawable drawer

4-pole 1/2 UNIT withdrawable drawer

Available degrees of protection: IP30-IP42-IP55

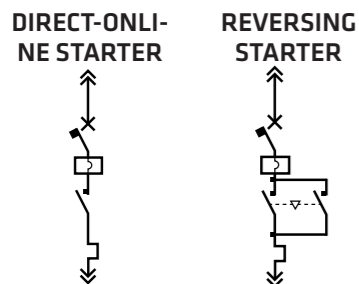

Motor starting typologies 1/2 UNIT

400 V			690 V		
Withdrawable drawer height mm	Direct-online starter kW	Reversing starter kW	Withdrawable drawer height mm	Direct-online starter kW	Reversing starter kW
150	≤ 7.5	≤ 7.5	150	≤ 7.5	≤ 7.5
200	≤ 11	≤ 11	200	≤ 18.5	≤ 18.5
250	≤ 18.5	≤ 18.5	250	≤ 22	≤ 22

Withdrawable drawer 1/2 FEEDER

Suitable for applications from 16A up to 100A

OUTGOING LINE

3-pole 1/2 FEEDER withdrawable drawer

4-pole 1/2 FEEDER withdrawable drawer

Available degrees of protection: IP30-IP42-IP55

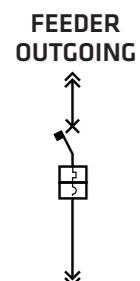

Motor starting typologies 1/2 FEEDER

400 V / 690 V	
Altezza cassetto mm	Corrente nominale A
150	≤ 35
200	≤ 80
250	≤ 100

Withdrawable drawer UNIT

Overview

1. SwitchLAF 2.0 system
2. Auxiliary connectors
3. Outgoing contacts (power pliers)
4. Sheet metal bracket for motor protection circuit breaker
5. 5 position switches
6. Lockable drawer for additional protection against incorrect operations

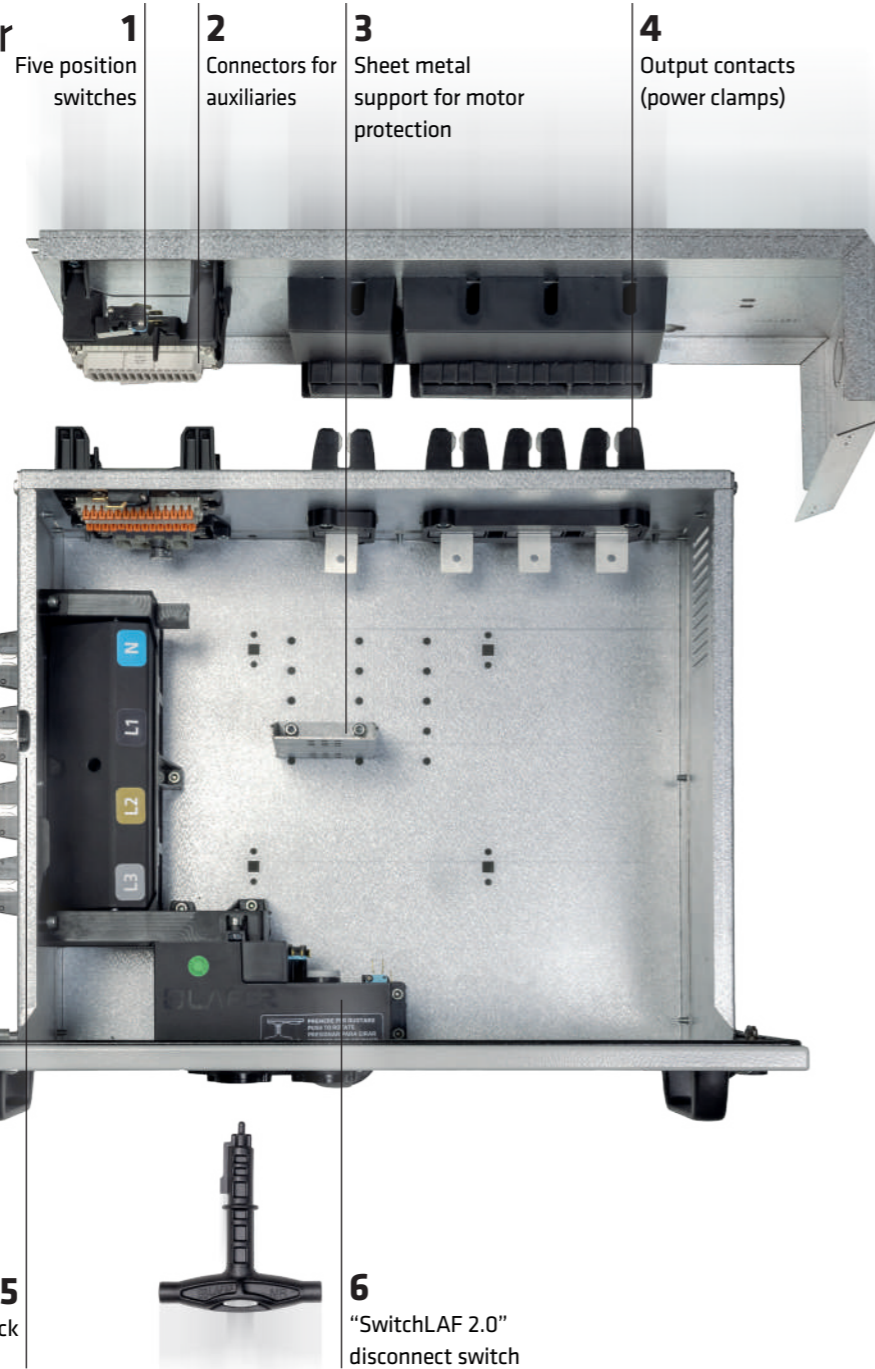

5
Drawer safety lock

6
"SwitchLAF 2.0"
disconnect switch

Accessories and main features



Safety features:
Drawer lockable in withdrawn position.



Safety features:
Padlockable drawer in case of a temporary breakdown.

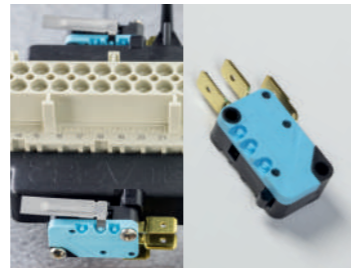

5 position switches - drawer:
- in "Test" position
- in "Disconnected/ Connected" position
- in "Inserted/Withdrawn" position
- in "Inserted/Withdrawn/Remote" position (n°2)



Withdrawable units coding:
Optional drawers identification system allowing an easy and unique identification of the position of each drawer in the cabinet.



Customizable connectors:
24 pins, 42 pins or double connector.

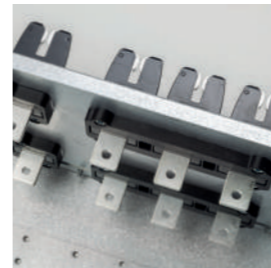

Double outgoing plier:
Double outgoing plier for star-delta starters.

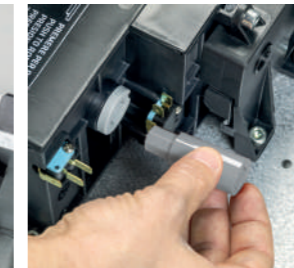

Universal shaft adapters:
3 different interchangeable shaft adapters compatible with all types of circuit breakers installed.



Connectors available on request: Wide range of special connectors available on request for Profibus, Modbus, Ethernet protocols etc.



Earthing: Self-centering grounding system.

Electrical data

Electrical data		Rated insulation voltage (U_i)	1000 V
Voltage ratings	Rated operational voltage (U_e)	400 / 500 / 690 V	
	Rated impulse withstand voltage (U_{imp})	6 / 8 / 12 Kv	
	Rated frequency (f_n)	50 / 60 Hz	
	3-pole or 4-pole version*		
Power pliers	Rated current [I_n]	160 / 320 A	
	Rated short-circuit current [I_p]	15 / 38 kA	
Auxiliary connectors	Rated current [I_n]	10 / 16 A	
	N° of auxiliary contacts	24 / 42 / 48	
Auxiliary contacts	Rated current [I_n]	16 A	
	N° of cycles	20.000.000	
	Contact type	2 changeover contacts	
	Connection type	Fast-on 6,3 mm	
Mechanical Characteristics	Drawers width (l)	625 / 700	
	Drawers height (h)	150 / 200 / 250 / 300 / 350 / 400 / 450 / 500 / 600	

*Not available for cabinets 625 mm wide

3-Pole
withdrawable
drawer
IP30/IP42
W=625

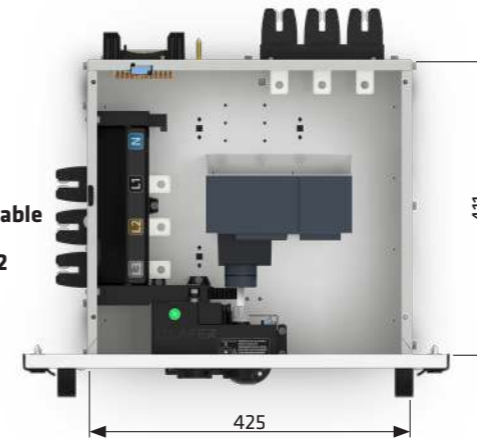

3-Pole / 4-Pole
withdrawable
drawer
IP30/IP42
W=700



3-Pole /
4-Pole
withdrawable
drawer
IP55
W=700

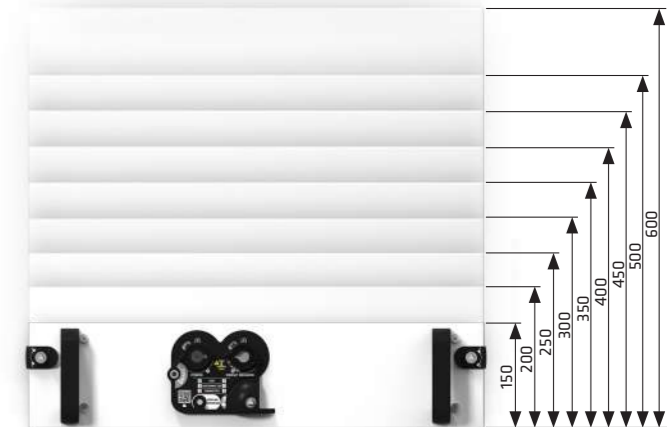

Withdrawable drawer 1/2 UNIT

Overview

1. SwitchLAF 2.0 system
2. Auxiliary connectors
3. Outgoing contacts (connectors)
4. Sheet metal bracket for motor protection circuit breaker
5. 5 position switches
6. Lockable drawer for additional protection against incorrect operations

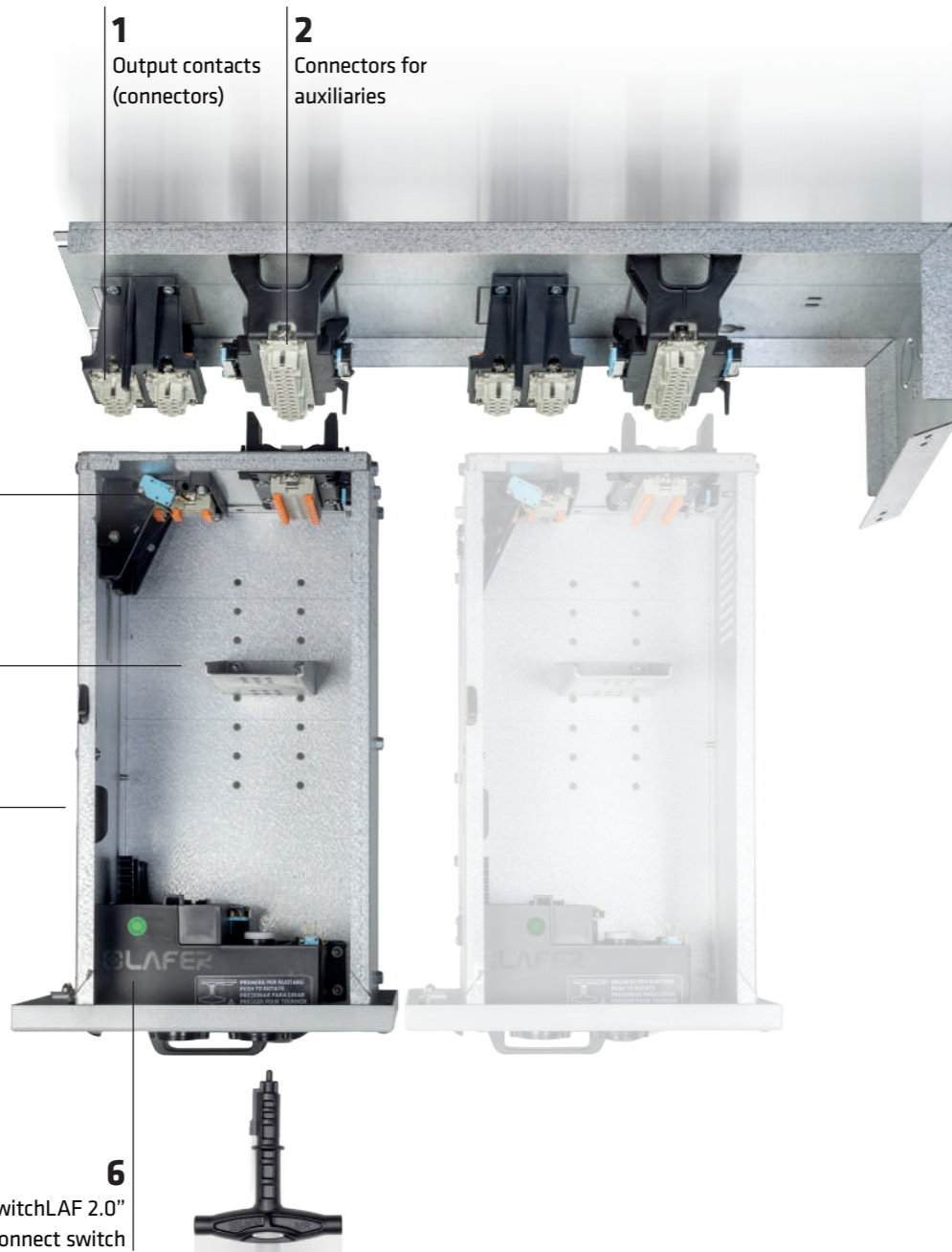

Accessories and main features



Safety features:
Drawer lockable in withdrawn position.



Safety features:
Padlockable drawer in case of a temporary breakdown.

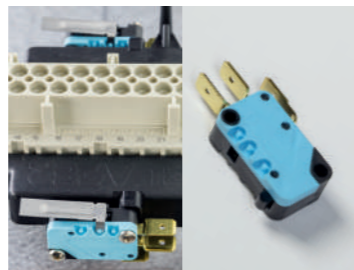

5 position switches - drawer:
- in "Test" position
- in "Disconnected/ Connected" position
- in "Inserted/Withdrawn" position
- in "Inserted/Withdrawn/Remote" position (n°2)



Withdrawable units coding:
Optional drawers identification system allowing an easy and unique identification of the position of each drawer in the cabinet.

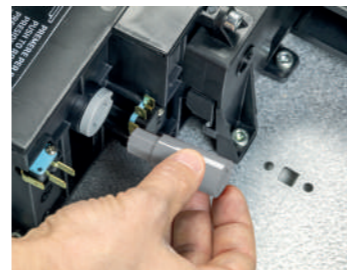

Universal shaft adapters: 3 different interchangeable shaft adapters compatible with all types of circuit breakers installed.



Connectors available on request: Wide range of special connectors available on request for Profibus, Modbus, Ethernet protocols etc

Electrical data

Electrical data		
Voltage ratings	Rated insulation voltage (U _i)	1000 V
	Rated operational voltage (U _e)	400 / 500 / 690 V
	Rated impulse withstand voltage (U _{imp})	6 / 8 / 12 Kv
	Rated frequency (f _n)	50 / 60 Hz
Power contacts	Rated current [In]	16A
	Rated currente [In]	10 / 16A
Auxiliary connectors	N° of auxiliary contacts	24 / 42
	Rated current [In]	16 A
Auxiliary contacts	N° of cycles	20.000.000
	Contact type	2 changeover contacts
	Connection type	Fast-on 6,3 mm
Mechanical Characteristics		
Drawers width (l)		350
Drawers height (h)		150 / 200

3-Pole / 4-Pole withdrawable unit
IP30/IP42
W=350

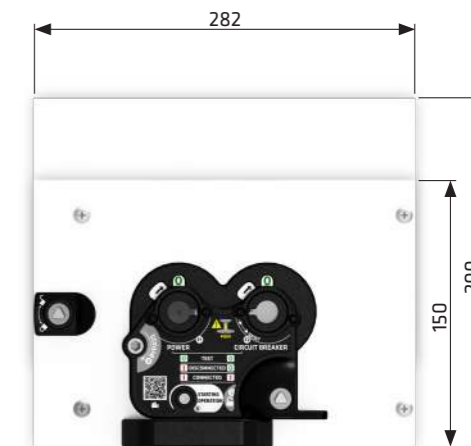

Operation of UNIT and 1/2 UNIT drawers Commissioning of the drawer



1. Drawer in "test" position

Push the test button (grey button) with the aid of SwitchLAF™ Key. The circuit will open and the physical correct insertion of the drawer checked. In case of a positive test, the hole allowing the performance of operation no.02 will open

2. Drawer in "disconnected" position

Insert SwitchLAF™ Key into the left-hand side hole, press and rotate 180° clockwise until the position "I" is reached. In this way the right-hand hole will open allowing the subsequent performance of operation no.3

3. Drawer in "connected" position

Press and rotate clockwise till reaching position "I"

Replacement of the drawer



1. Drawer in "connected" position

Insert SwitchLAF™ Key into the right-hand side hole, press and rotate 180° anticlockwise until the position "0" is reached.

2. Drawer in "disconnected" position

Insert SwitchLAF™ Key into the left-hand side hole, press and rotate 180° anticlockwise until the position "0" is reached.

Test of the drawer



Test by-pass

While the drawer is in Test position it is possible to carry out the electrical test downstream the main circuit breaker of the drawer.

Insert an Allen key (size n° 6) into the appropriate space as shown in the figure, rotate clockwise until hole "F2" is completely opened.

Insert SwitchLAF™ Key into "F2" hole and power the circuit breaker by rotating the key 180° clockwise until the position "I" is reached.

SwitchLAF™ 2.0 SwitchLAF™ 2.0 positions

SwitchLAF™ positions	Circuits	Safety locks	Position of the drawer
	0 0 WITHDRAWN Main circuit opened Auxiliary circuits opened	The drawer can be locked by padlock	The drawer is advanced by 20 cm from the cabinet
	0 I TEST BY PASS Main circuit opened Auxiliary circuits closed	SwitchLAF™system can be locked by padlock	The drawer is physically inserted and blocked in the cabinet
	0 0 STARTING OPERATION Main circuit opened Auxiliary circuits closed	SwitchLAF™system can be locked by padlock	The drawer is physically inserted and blocked in the cabinet
	I 0 DISCONNECTED Main circuit opened Auxiliary circuits closed		The drawer is physically inserted and blocked in the cabinet
	I I CONNECTED Main circuit closed Auxiliary circuits closed		The drawer is physically inserted and blocked in the cabinet

Withdrawable drawer 1/2 FEEDER

Overview

1. SwitchLAF 2.0 system
2. Auxiliary connectors
3. Outgoing contacts (connectors)
4. Sheet metal bracket for motor protection circuit breaker
5. Lockable drawer for additional protection against incorrect operations

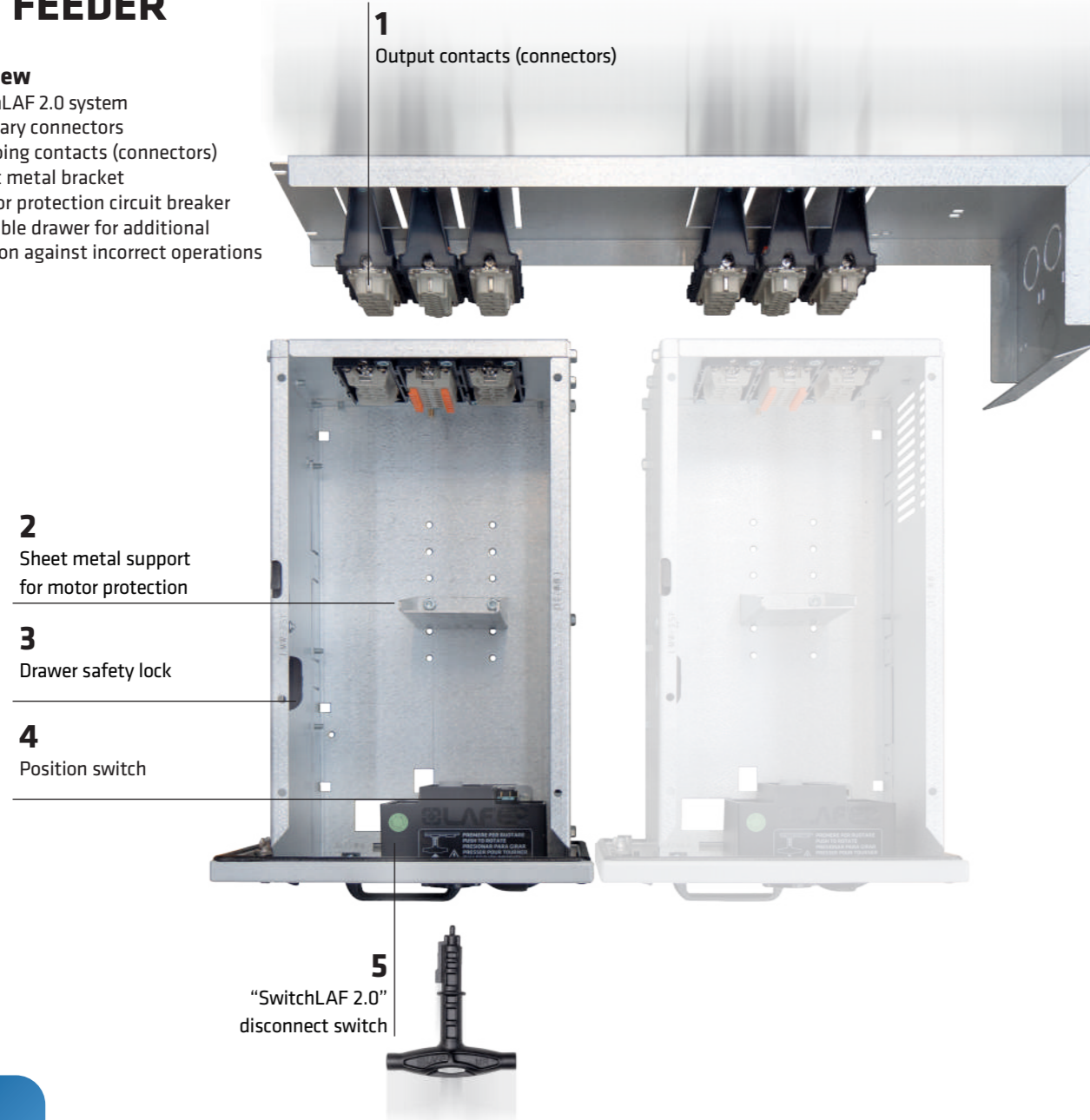

Accessories and main features



Safety features:
Drawer lockable in withdrawn position.



Safety features:
Padlockable drawer in case of a temporary breakdown.



Withdrawable units coding:
Optional drawers identification system allowing an easy and unique identification of the position of each drawer in the cabinet.

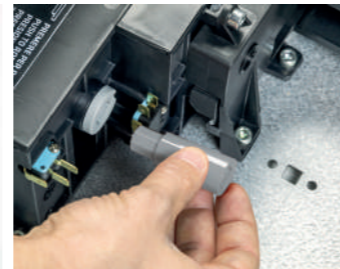

Universal shaft adapters:
3 different interchangeable shaft adapters compatible with all types of circuit breakers installed.



Connectors available on request:
Wide range of special connectors available on request for Profibus, Modbus, Ethernet protocols etc.



Earthing:
Self-centering grounding system

Electrical data

Electrical data		
Voltage ratings	Rated insulation voltage (U _i)	1000 V
	Rated operational voltage (U _e)	400 / 500 / 690 V
	Rated impulse withstand voltage (U _{imp})	6 / 8 / 12 Kv
Power contacts	Rated frequency (f _n)	50 / 60 Hz
	Rated current [I _n]	35 / 80 / 100 A
Auxiliary connectors	Rated current [I _n]	16A
	N° of auxiliary contacts	16*
Auxiliary contacts	Corrente nominale [I _n]	16 A
	Rated current	20.000.000
	Contact type	2 changeover contacts
	Connection type	Fast-on 6,3 mm
Mechanical Characteristics		
Drawers width (l)		350
Drawers height (h)		150 / 200

*The number of auxiliary contacts varies based on the connectors installed

3-Pole / 4-Pole
withdrawable unit
IP30/IP42 W=350

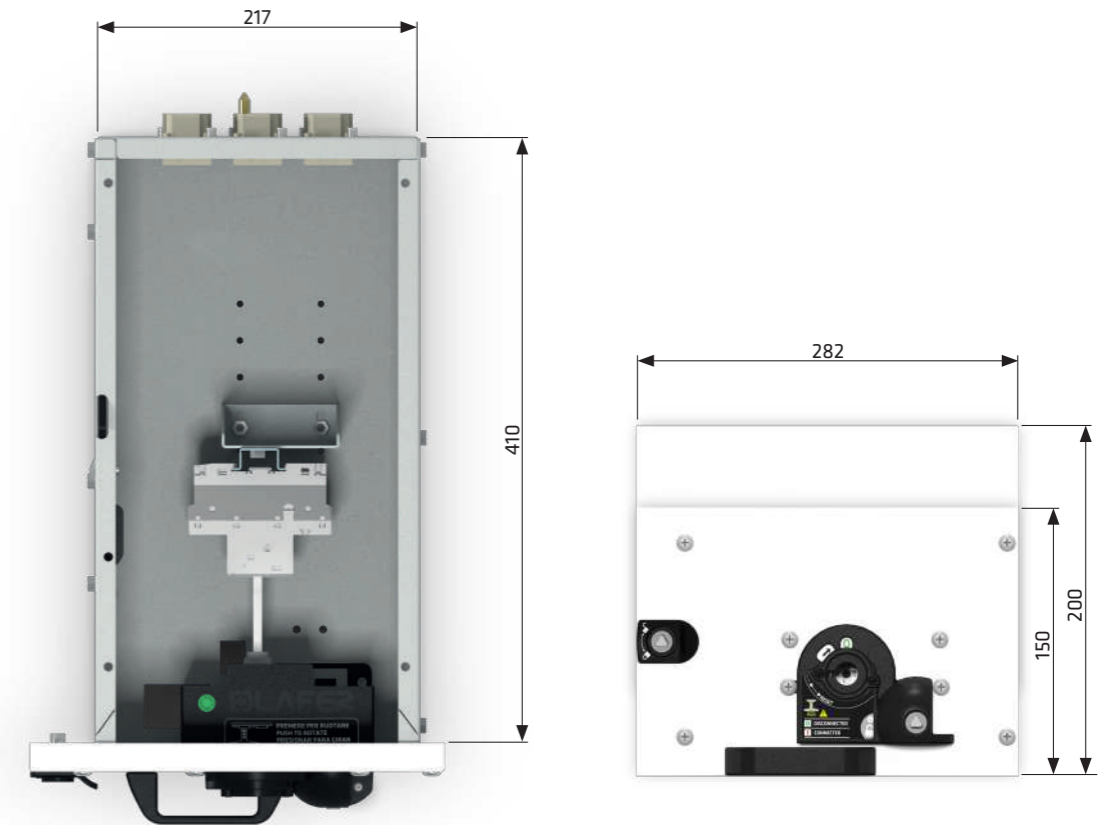

Operation of FEEDER drawers Commissioning of the drawer



1. Drawer in "service" position
Insert the key into the operating hole, press to rotate 90° clockwise until reaching position "1".

2. Drawer in "extracted" position
From the "service" position, carry out the operation backwards.

SwitchFEED™ 2.0 SwitchFEED™ 2.0 positions

SwitchFEED™ 2.0 positions	Circuits	Safety locks	Position of the drawer
	0 WITHDRAWN Main circuit opened Auxiliary circuits opened	The drawer can be locked by padlock	The drawer is advanced by 20 cm from the cabinet
	I CONNECTED Main circuit closed Auxiliary circuits closed		The drawer is physically inserted and blocked in the cabinet



LAFER GROUP S.P.A.

Via A. Santurro, 3 - 36040 Meledo di Sarego (Vicenza) Italy

T. +39 0444 490562 - lafer@lafer.com

www.lafer.com

